

POWER Ups

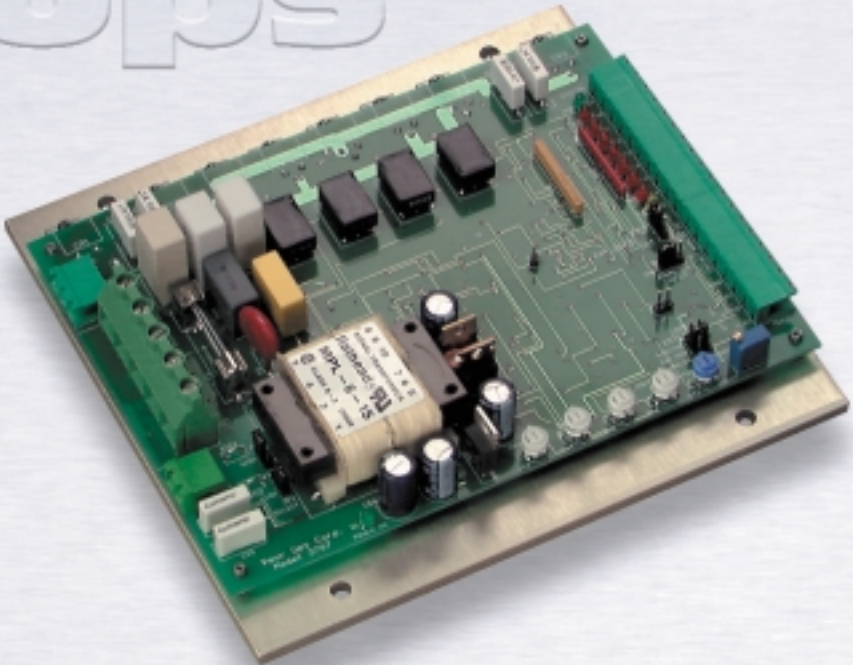

Model 2767

Installation and Operating Instructions
Full Wave Regenerative Motor Control

Application Handbook

Table of Contents

	Page(s)
Specifications	3
General Description	4
Connections	4-8
Transformers	8-9
Calibration	10-12
Trouble Shooting	13
Connection & Input Diagrams	14-15
Limited Warranty	16

Copyright © 2000 by
Powr Ups Corporation

All rights reserved. No part of this manual may be reproduced or transmitted in any form without written permission from Powr Ups Corporation. The information and technical data in this manual are subject to change without notice. Powr Ups Corp. makes no warranty of any kind with respect to this material, including, but not limited to, the implied warranties of its merchantability and fitness for a given purpose. Powr Ups Corp. assumes no responsibility for any errors that may appear in this manual and makes no commitment to update or to keep current the information in this manual.

Printed in the United States of America.



CAUTION!

Hazardous voltages are exposed during the set up and operation of this unit. Exercise caution - only qualified personnel should perform adjustment of this unit.

SPECIFICATIONS

Electrical Ratings:

AC Line Voltage

115VAC \pm 10% 50/60Hz Single Phase

230VAC \pm 10% 50/60Hz Single Phase

Form Factor

1.37 at Base Speed

Accel/Decel Range

0.5-6 Seconds

Analog Input Voltage Range

\pm 5 VDC

\pm 10 VDC

Input Impedance

30 k Ω

Load Regulation

1% Base Speed

Temperature Range

10°C-70°C

Weight

Approximately 2 lbs.

Field Voltages

115VAC: 50 to 100 VDC

230VAC: 100 to 200 VDC

Max Armature Current	Horse Power Range	Armature Voltage
5.0	½	90 VDC
10.0	1	90 VDC
5.0	1	180 VDC
10.0	2	180 VDC

GENERAL DESCRIPTION

The Model 2767 Motor Controls are fullwave, regenerative (four quadrant) SCR type controls that control the speed and direction of shunt wound or permanent magnet DC motors. The Model 2767 offers a variety of customer interface configurations. The customer can interface with the unit via either an 8 bit TTL level input command, a fully isolated analog input, or a manual speed potentiometer. The input signal circuitry is isolated from the AC mains and motor terminals with a minimum of 1500-volt DC dielectric withstanding voltage. These controls are designed to be easily interfaced to microprocessors or digital circuitry. The opto-isolation between the logic inputs and power line and motor outputs eliminates the possibility of grounding or noise problems.

The Model 2767 can also drive motors with 12, 24, 48, & 130VDC armature ratings. An external transformer connected to the TB5 terminal block will be selected for a particular motor voltage and power to get the best form factor for the motor.

CONNECTIONS

DIGITAL INTERFACE (2767D)

Configure the Input Interface jumper to the Digital position.

The eight bit parallel command consists of one bit for direction and seven bits for motor speed. In addition, a failsafe circuit de-energizes the motor if the control power is not present. Note, to switch input setting, remove jumper from digital position and place on either one of the other two settings as required per your application. At factory, the input interface jumper is placed on the digital position.

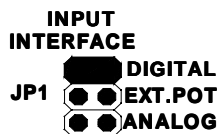

Jumper should be installed horizontally!

The input coding is negative true as follows:

TB2

Pins 1 Positive Common ($V_{cc} = 4.5$ to $5.5VDC$)

Pins 2 Polarity Bit (low = CW, high = CCW)

Pins 3 Speed Control MSB, negative active

Pins 4 Speed Control Bit 5, negative active

Pins 5 Speed Control Bit 4, negative active

Pins 6 Speed Control Bit 3, negative active

Pins 7 Speed Control Bit 2, negative active

Pins 8 Speed Control Bit 1, negative active

Pins 9 Speed Control Bit 0 LSB, negative active

Pins 10 Negative Common

Pins 2-9 are standard TTL loads

Full speed CW is obtained with pins 2-9 grounded. Full speed CCW is obtained with pin 2 high (or open) and pins 3-9 grounded. Zero speed is obtained with pins 3-9 open or high. Internally adjustable armature voltage feedback allows speed control over a 50:1 minimum range, with a 7-bit resolution.

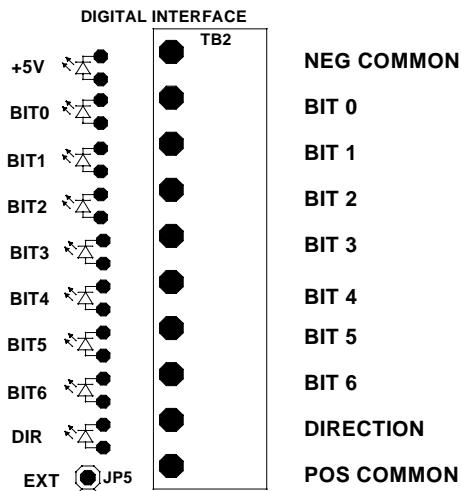

Digital Interface

ANALOG INTERFACE (2767A)

Configure the Input Interface jumper to the Analog position. Note, to switch input setting, remove jumper from digital position and place on either one of the other two settings as required per your application. At factory, the input interface jumper is placed on the digital position. These controls are easily interfaced to low level analog circuitry. The voltage level and polarity of the input signal (10VDC Max) determine motor speed and direction. Input signals are isolated from the motor and power line with a minimum isolation voltage of 1500VDC. This reduces the possibility of grounding, noise or safety problems.

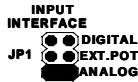

Set programmable jumper JP6 Analog Input selector to the correct input configuration (5VDC or 10VDC). Install jumper in the location of the input voltage used in your application. If using 10VDC you must remove jumper to Gain (JP2).

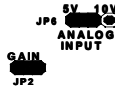

TB4 CONNECTIONS

TB4-1: Analog Input (5VDC or 10VDC)

Tb4-2: Analog Return



MANUAL SPEED POT INTERFACE (2767P)

Configure the Input Interface jumper to the EXT. POT position. The Model 2767 can be easily configured with a 10K speed pot. The control can be wired for either a unidirectional or bi-directional application. The output of the motor control is dependent on the adjustment of the speed pot. The output voltage of the control will be linear versus pot rotation. Due to the regenerative action of the control the motor will decelerate to zero speed rapidly versus a unidirectional type control.

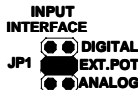

Jumper should be installed horizontally!

TB6 CONNECTIONS

TB6-1: Inhibit 1

TB6-2: Inhibit 2

TB6-3: Potentiometer CCW Arm (Gnd) *Only for uni-directional use

TB6-4: Potentiometer CCW

Arm (-12Vdc) *Only for bi-directional use

TB6-5: Potentiometer Wiper (Input)

TB6-6: Potentiometer CW Arm (+12Vdc)

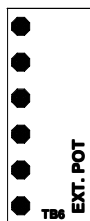

INHIBIT 1

Regenerative Brake

INHIBIT 2

Inhibit

GND

-12V

WIPER

Speed Pot Interface

+12V

FAILSAFE

The failsafe circuitry is an interlock; when not energized the unit will be in-operable. Configure the programmable jumper JP5 for External or Internal failsafe operation. At factory a jumper is placed on EXT position.

External Failsafe Operation- Configure programmable jumper JP5 to the EXT position.



This circuitry must be properly connected or the unit will not operate! A positive DC voltage source greater than 4.5VDC but less than 5.5VDC must be connected between TB2-1(+) & TB2-10 (-). The external failsafe circuitry de-energizes the motor if the 5VDC power is not present. This is a freewheeling operation and shouldn't be used for a fast responding stop condition.

Internal Failsafe Operation- if the failsafe operation isn't needed for customers application unit can operate on it's internal power supply. Configure programmable jumper JP5 to the INT position.

INHIBIT (Regenerative Brake)

TB6-5 & TB6-6 are the 2 terminals that are used to regeneratively brake the motor. This function is accomplished by shorting out these 2 terminals. Reopening the terminals causes the motor to accelerate to its preset speed. When wiring to these 2 points be careful to separate these wires from the power and motor output wiring or any other power connections which would create electrical noise. Do not use this feature for emergency stopping, always shutdown the AC power connecting the drive to assure that the control can't provide any output.

LINE VOLTAGE CHARACTERISTICS

The Model 2767 motor control is factory set for 115VAC input. The control can easily be configured for 230VAC by changing the programmable jumpers for the 230VAC input positions. The allowable range in voltage is $\pm 15\%$ this corresponds to a range of 100VAC to 130VAC or 200VAC to 260VAC. Other input voltages are available on special order from the POWR-UPS factory.

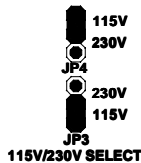

The units are factory set for 60Hz ($\pm 3\text{Hz}$) operation, but can easily be re-configured for 50Hz operation. This is accomplished by removing the 50/60Hz jumper.



Motor Selection Criteria

Unless specified, Model 2767 controls are factory set for 115VAC input and 90VDC output. For 230VAC, inputs reconfigure programmable jumpers JP3 & JP4 for 230VAC position. The industry standard armature voltage for this input voltage rating is 180VDC. Any motor with a different armature rating may become damaged if connected to the control with 230VAC input power.

12,24,48,130VDC Rated Motors

If your application calls for a motor with a non-standard armature voltage, POWR-UPS can accommodate your application. For these application you will need to order an auxiliary transformer that will get connected to the Aux. Xfmr connector on the unit. The transformer will provide the correct voltage needed to provide a nearly optimum form factor for best motor performance and longevity. The recommended auxiliary transformer part numbers depend on motor ratings and are as follows:

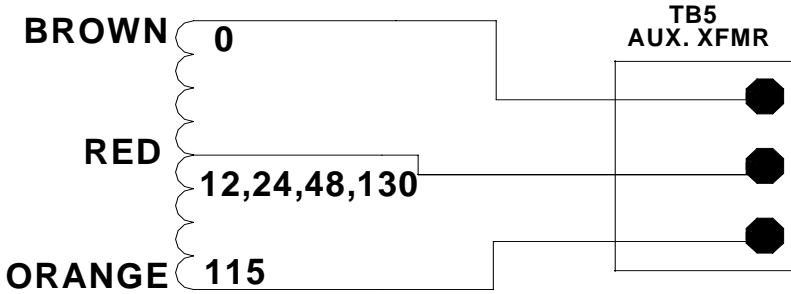

Transformer Physical Parameters

Armature Voltage	HP Range	Part Number
12VDC	1/50-1/4 1/4-1/2	T12.25 T12.50
24VDC	1/50-1/4 1/4-1/2	T24.25 T24.50
48VDC	1/4-1/2	T48.50
130VDC	1/4-1/2	T130.50

Size	Height	Width	Length	Weight
.25	.2875	2.468	4.500	3.0 Lbs
.50	3.437	3.000	4.125	5.5 Lbs

INSTALLATION AND CALIBRATION INFORMATION

The control has been factory tested and adjusted with an actual motor load and should not require field re-adjustment.

The control should be set up with the actual input voltage and motor load, if available. If the motor is not available, a suitable alternate motor or dummy load should be used.

The following adjustments are provided:

Maximum Speed Adjustment (R43),

This sets the motor's top end voltage and functions as a gain control for both CW and CCW commands.

I.R. Compensation (R44),

This control is used for setting the amount of IR compensation in order to optimize open loop speed regulation under variable loads.

Current Limit CW (R46),

This control is used to limit the maximum current delivered to the motor, hence the torque delivered to the load. This adjustment is factory preset at the maximum setting. The current limit may be adjusted lower for the protection of motors less than the maximum HP. Since the response is relatively slow acting, this function can not be used for output short circuit protection.

Current Limit CCW (R45),

This control is used to limit the maximum current delivered to the motor, hence the torque delivered to the load. This adjustment is factory preset at the maximum setting. The current limit may be adjusted lower for the protection of motors less than the maximum HP. Since the response is relatively slow acting, this function cannot be used for output short circuit protection.

Accel/Decel (R42),

This control is used to determine the time the motor takes to accelerate to a higher speed, or decelerate to a lower speed in the forward or reverse direction, within the limits of available torque. The Accel/Decel setting is factory set for its fastest forward acceleration and deceleration time (fully CCW). Turn the Accel/Decel trimpot CW to increase the acceleration and deceleration time, or CCW to decrease the acceleration and deceleration time. Accel/Decel time range is 0.5-6 seconds.

Analog Input Offset (R117),

This control is used when the unit is set up for an analog input interface. When the unit is supplied with a 0VDC analog input the output voltage should be 0VDC. If there is an output voltage when the unit is set up for 0VDC, adjust R117 to null the output voltage to 0VDC.

PROGRAMMABLE JUMPERS**50/60Hz Selection:**

For 50Hz operation, remove the 50/60Hz jumper. The unit is factory preset for 60Hz operation.

115VAC/230VAC Input Selection:

For 230VAC operation, reconfigure jumpers to the 230VAC positions. The unit is factory preset for 115VAC operation.

FAILSAFE:

If failsafe operation isn't needed for customers application, unit can operate on its internal power supply. Reconfigure jumper to the internal position. The unit is factory preset for external operation.

DIGITAL/ANALOG/POT INPUT:

The control is setup for a digital input from the factory. Remove jumper and replace in the analog or pot position if application requires analog or manual pot input.

ANALOG INPUT VOLTAGE (5VDC/10VDC):

The control is setup for 5VDC operation from the factory. Remove jumper and replace in the 10VDC position for this application.

Mounting:

The Model 2767 units may be secured to the mounting surface by 8-32 UNC-2B screws (rear mounting). The unit should be mounted in a dry area and not subject to excessive shock and vibration. Operating ambient temperature range is -20°C to +70°C. The drive must be earth grounded for noise suppression. Connect earth ground to TB1-5 or directly to the chassis.

Connections:

Use suitably sized conductors (#14-#16 AWG recommended) for motor armature and power line connections. Wire up to #26 AWG may be used for signal input connections. The Model 2767 motor controls are supplied with removable connectors for the signal input connections to allow field replacement without re-wiring.

FIELD VOLTAGE:

For 115VAC units powering motors requiring a 100 volt DC field, connect the field wires between F1 (Field +) and F2 (Field -) of TB3. If the motor requires a 50VDC field, connect the field wires between F1 (Field + TB3) and L2 (AC line return) power connector.

For 230VAC units powering motors requiring a 200-volt DC field, connect the field between F1 (Field +) and F2 (Field -) of TB3. For a 100-volt DC field, connect between F1 (Field + TB3) and L2 (AC line return) power connector.

Permanent Magnet (PM) motors do not require a field connection.

Internal Fuse:

A Buss (or equivalent) MDA15, 15 ampere, 250VAC slow blow fuse is mounted internally in clips. Repeated fuse blowing should be investigated as it may damage the unit.

Diagnostic LED's:

- (8) T-1 LED's for monitoring Digital interface
- (1) LED to monitor +5VDC power supply.
- (1) LED to monitor power on.

Perform the following steps prior to starting the troubleshooting procedure:

- Disconnect the AC power from the unit.
- Inspect the unit for damaged components.
- Confirm that all connections are tightened properly to the terminal blocks.
- Confirm all programmable jumpers are in the appropriate settings for your particular application.
- Verify that all wiring to the unit is free of short circuits.
- Check all power sources are set properly prior to energizing the unit.

In case of operating or installation difficulty, call the POWR-UPS Application Department at (631) 345-5700.

TROUBLESHOOTING

PROBLEM	POSSIBLE CAUSE	SUGGESTED SOLUTIONS
Line fuse blows	<p>Fuse is wrong rating.</p> <p>Motor wiring shorted.</p> <p>Armature windings are connected to field connector.</p>	<p>Install correct fuse.</p> <p>Check wiring and correct problem.</p> <p>Replace fuse and confirm field diodes are okay.</p>
Control has no output	<p>Speed adjust pot is set to zero speed.</p> <p>Speed pot isn't connected properly.</p> <p>Failsafe is configured for EXT.</p> <p>Max Torque Pots are adjusted fully CCW.</p> <p>Inhibit terminations are jumpered.</p> <p>AC voltage not applied to the unit.</p> <p>Motor load is not connected.</p>	<p>Increase the speed pot setting.</p> <p>Confirm pot wiring.</p> <p>Confirm you have 5VDC across TB2 connections.</p> <p>Adjust R45 & R46 to midpoint.</p> <p>Confirm TB6-5,6 are open.</p> <p>Check AC connections.</p> <p>Check motor connections.</p>
Motor speed too fast	<p>Max speed pot not calibrated.</p>	<p>Adjust R43.</p>
Motor doesn't reach desired speed.	<p>Max speed pot setting is too low.</p> <p>Max torque pot setting is too low.</p> <p>Motor is overloaded.</p> <p>Input signal isn't sufficient for full speed.</p>	<p>Recalibrate control.</p> <p>Recalibrate control.</p> <p>Check motor load, resize if necessary.</p> <p>Check Analog, Digital, and Pot interface to confirm correct settings.</p>
Motor output unstable	<p>IR comp is set too high.</p> <p>Hitting current limit.</p>	<p>Adjust R44 CCW.</p> <p>Adjust R45 & R46 CW.</p>

CONNECTION DIAGRAM

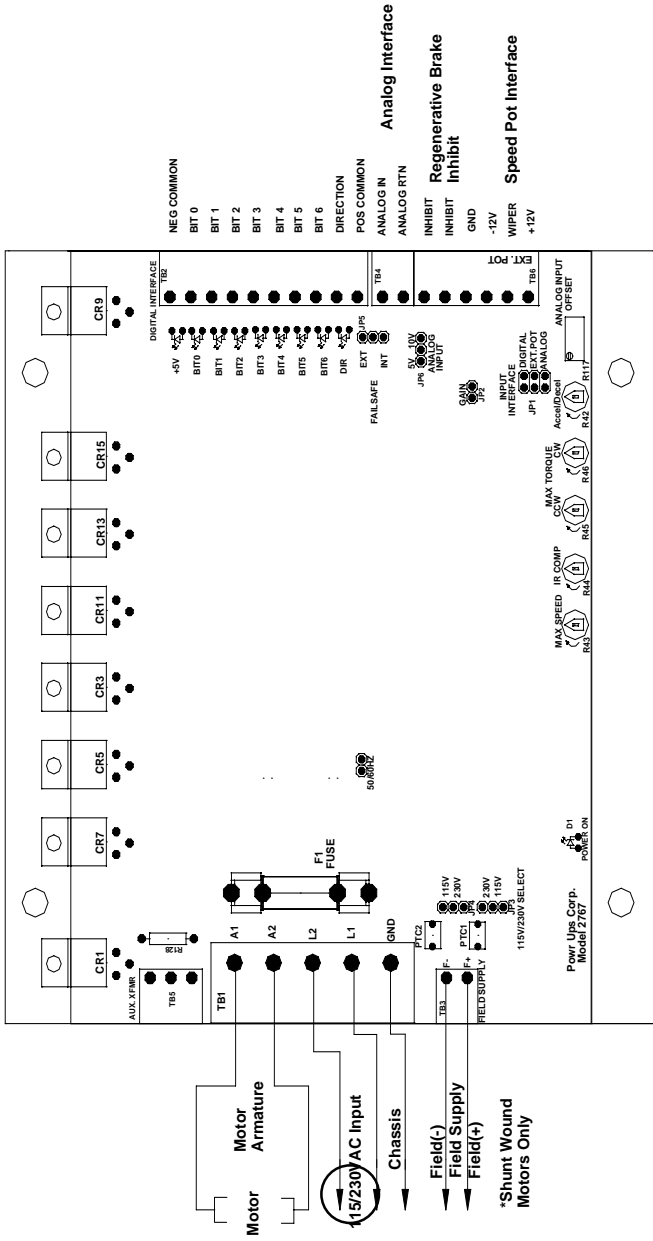

INPUT CONNECTION DIAGRAM

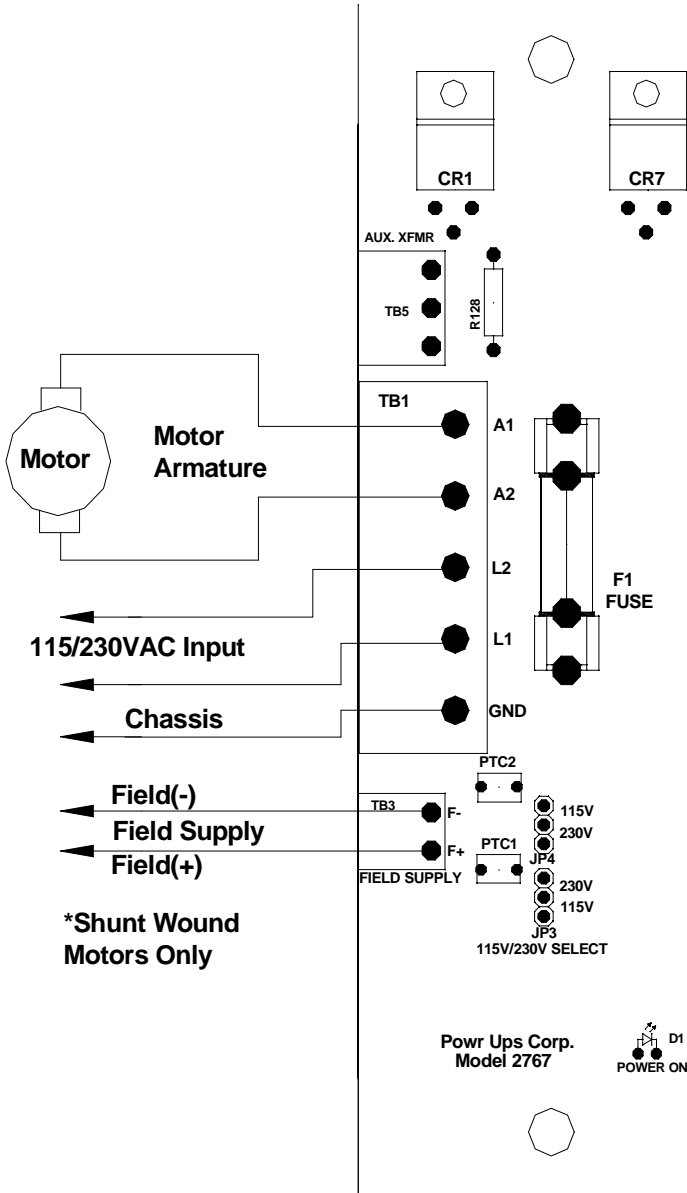

LIMITED WARRANTY

For a period of 12 months from the date of original purchase, we will repair or replace without charge, devices which our examination proves to be defective in material or workmanship. This warranty is valid if the unit has not been tampered with by unauthorized persons, misused or abused and has been used in accordance with the instructions or ratings expressed or implied, and we are not responsible for any expense, inconvenience, or any consequential damages caused by items of our manufacture or sale. All controls should be returned by contacting our office at (631) 345-5700. We then will issue an Return Material Authorization #, which needs to be shown on any return paperwork and on the outer side of the shipping carton.

A. RETURNS (IN WARRANTY): All controls deemed to be in warranty must be shipped prepaid to the factory for repair. Controls will be returned freight paid within the continental U.S.A..

B. RETURNS (OUT OF WARRANTY): Controls should be returned freight prepaid. They will be repaired and returned freight collect. Repairs will be billed to the distributor. Controls out of warranty and damaged beyond repair will not be repaired.

ANY QUESTIONS REGARDING THIS POLICY SHOULD BE REFERRED TO THE SALES DEPARTMENT. CALL (631) 345-5700.

2767 01

ZONE	REV	C/A	DATE	APPROVED

REVISIONS

DESCRIPTION

(4) MTG FOR #10 SCREWS

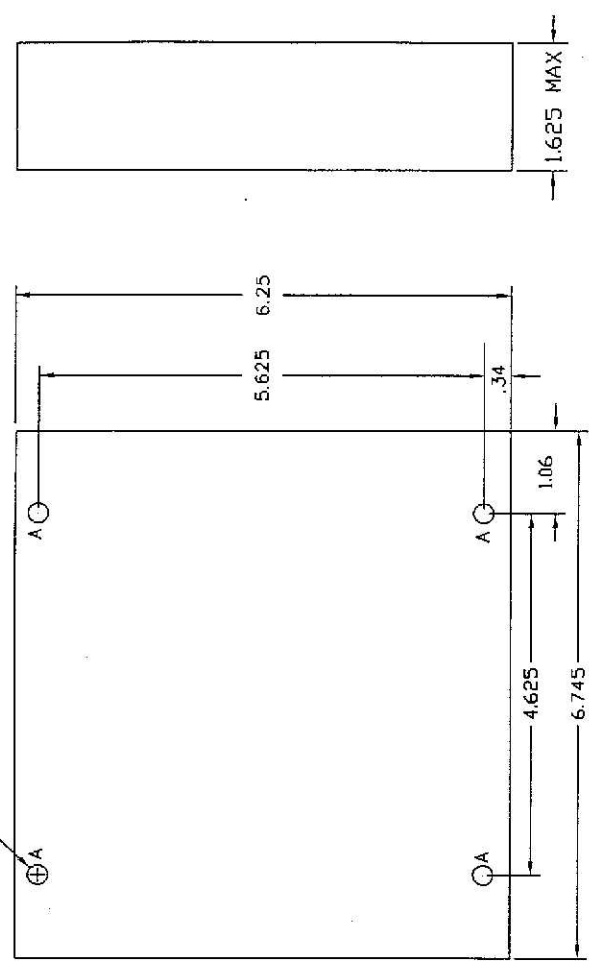

THIS DRAWING CONFORMS TO THE REQUIREMENTS OF ANSI Y14.5M-1982	DATE DRAWN BY CHECKED BY ENG APPROVAL OR APPROVAL MFG APPROVAL CONTRACT NO.	POWER UPS CORP. SHREY, NY 11887	
		2767 MOUNTING DIMENSIONS	
USE THE FOLLOWING DIMENSIONS UNLESS OTHERWISE SPECIFIED: FRACTIONS IN INCHES DECIMALS IN MILLIMETERS	SCALE 1" = 1"	PART NO. 2767-01	SHEET 1 OF 1
DO NOT SCALE DIMENSIONS FROM THIS DRAWING	MATERIAL TYPICAL	NET WT APPLICATION	SEE CASE ONE B 52202
MANUFACTURING DIMENSIONS SHALL BE ACCORDANCE WITH US SPECIFICATIONS	USED ON	MFG NO	REV

Model 2767 Full Wave Regenerative Motor Control

The Model 2767 is a full wave regenerative drive capable of operating DC permanent magnet or shunt wound motors in a bi-directional mode. Its four-quadrant operation provides forward and reverse torque in both directions. Because of its excellent response time the Model 2767 can replace servos in many applications. The Model 2767 is factory set for industry standard 90VDC and 180VDC motors, it can also accommodate 12, 24, 48, 130 VDC motors.

Features:

- Opto-Isolated 8 Bit Digital Inputs (7 bits speed resolution and direction bit), or
- 5V/10VDC fully isolated Analog Input, or
- External Manual Speed Pot Control
- 115V/230V AC Input
- Custom Armature Voltage Outputs available
- 1500 volt isolation (minimum)
- Diagnostic LED's for Digital Interface
- Internal/External opto-isolated Fail Safe Freewheeling Stop
- Inhibit Functions as Regenerative Stop
- Fully Isolated Digital or Analog Inputs
- External Manual Speed Pot
- AC Line Fuse
- PTC Resettable Fuses for Field Voltages and Internal Bias Supplies
- Removable type terminal blocks
- Surface Mount Technology

Jumper Selectable Features

- AC Line Voltage 115V/230V
- AC Line Frequency 50/60hz
- Fail Safe External or Internal Mode
- Analog Input Voltage 5VDC/10VDC
- Analog Gain
- Control Select Digital, Analog or External Pot

LED's

- Power On
- 8 Bit Digital Input Diagnostics

Trim Pot Adjustments

- Max Speed
- IR Compensation
- Maximum Torque Clockwise and Counter Clockwise
- Ramp Accel/Decel
- Analog Input Offset

Powr Ups Corp.

One Roned Road
Shirley, New York 11967

Tel 1 800 333 POWR or 1 631 345 5700

Fax 1 631 345 0060

www.PowrUpsCorp.com

(4) MTG FOR #10 SCREWS

